

biglia

B446, B465, B545, B565, B745, B765

Programa de portaherramientas



B446, B465, B545, B565, B745, B765

Programa Coromant Capto®

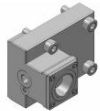

unidad de sujeción OD

C4	C4-TRE-BI55A	Estándar
C4	C4-TLE-BI55A	Estándar



Unidad de sujeción OD, doble, eje Y

C4	343-830111C1292	Para cotización
----	-----------------	-----------------



Unidad de sujeción OD, corta

C4	343-830111C1251	Para cotización
----	-----------------	-----------------



Unidad de sujeción OD, ambos lados, doble, eje Y

C4	343-830111C1293	Para cotización
----	-----------------	-----------------



Unidad de sujeción OD, ambos lados

C4	343-830111C671	Para cotización
----	----------------	-----------------

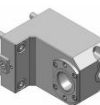

Unidad de sujeción de cara e identificación

C4	C4-TRI-BI55B	Estándar
C4	C4-TLI-BI55B	Estándar



Unidad de sujeción de cara e identificación

C5	343-830111C672	Para cotización
----	----------------	-----------------



Soporte de corte, ajustable, HP-IC

SH 32 APBR-BI55A-25-HP IC 80bar	Estándar
SH 32 APBL-BI55A-25-HP IC 80bar	Estándar



Unidad de taladrado/fresado OD

C3	343-830820N2864 1:1	CE	Para cotización
C3	343-830820N1968 1:1	CI 80 barras	Para cotización

B446, B465, B545, B565, B745, B765

Programa Coromant Capto®

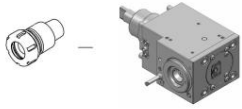

Unidad de fresado/taladro frontal

C3	343-830820N2860 1:1	CE	Para cotización
C3	343-830820N2861 1:1	Cl 80 barras	Para cotización

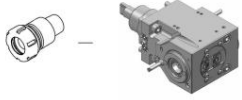

Unidad de fresado/taladro frontal, ambos lados

C3	343-830820N2862 1:1	CE	Para cotización
----	---------------------	----	-----------------

Cómo elegir la unidad de sujeción

Configuración interna

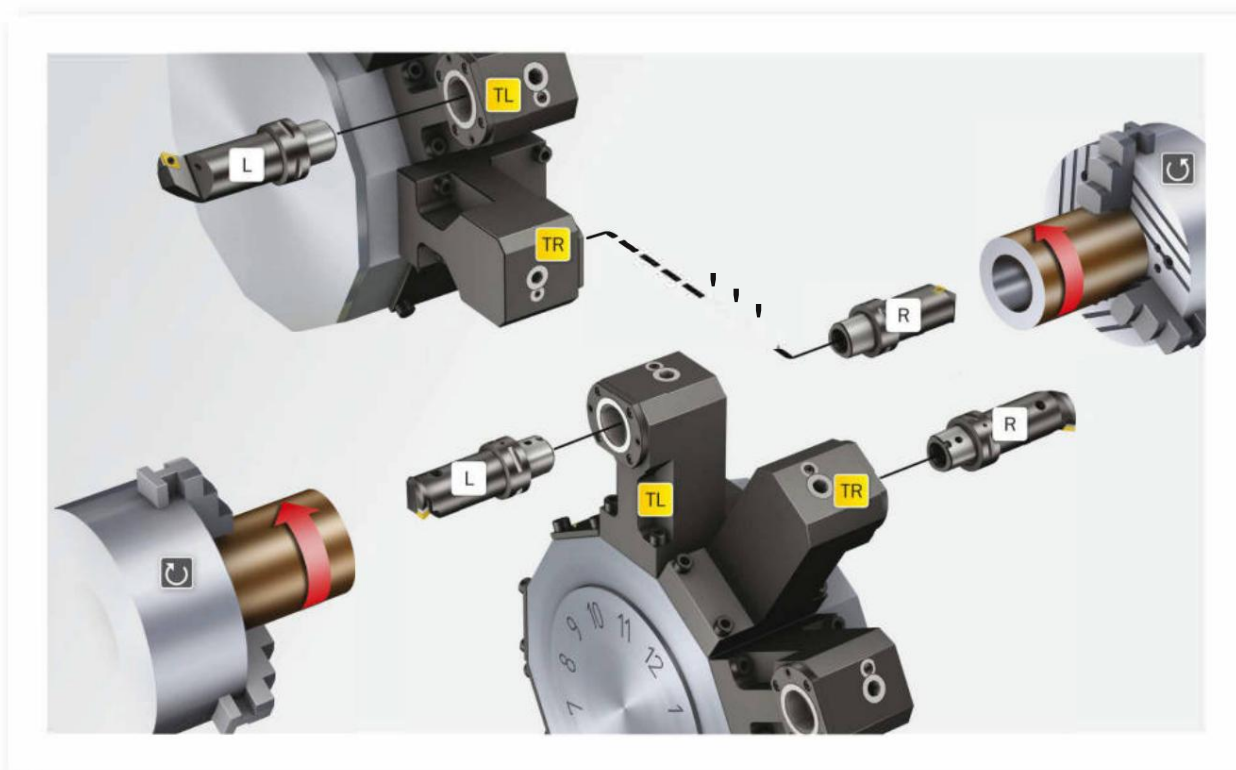

C

D

mi

Configuración externa

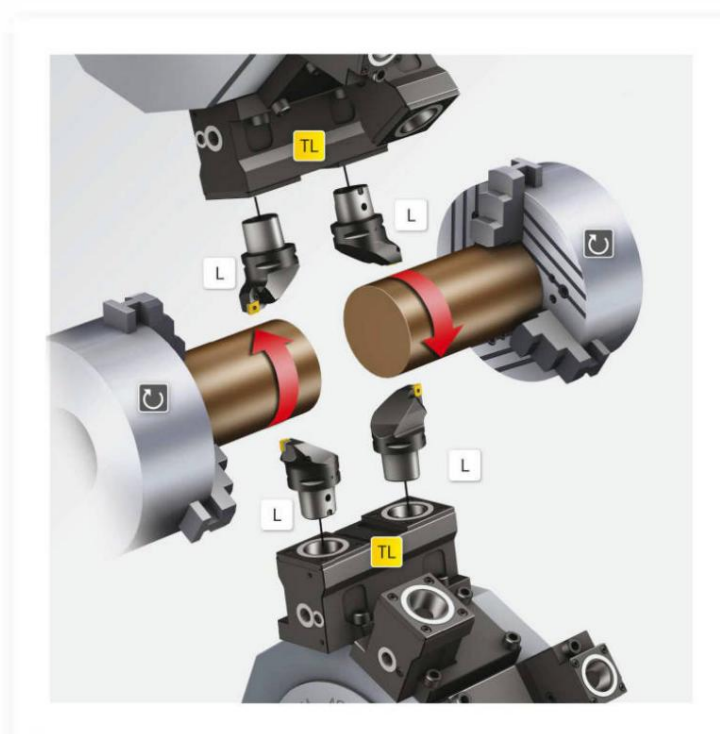

F





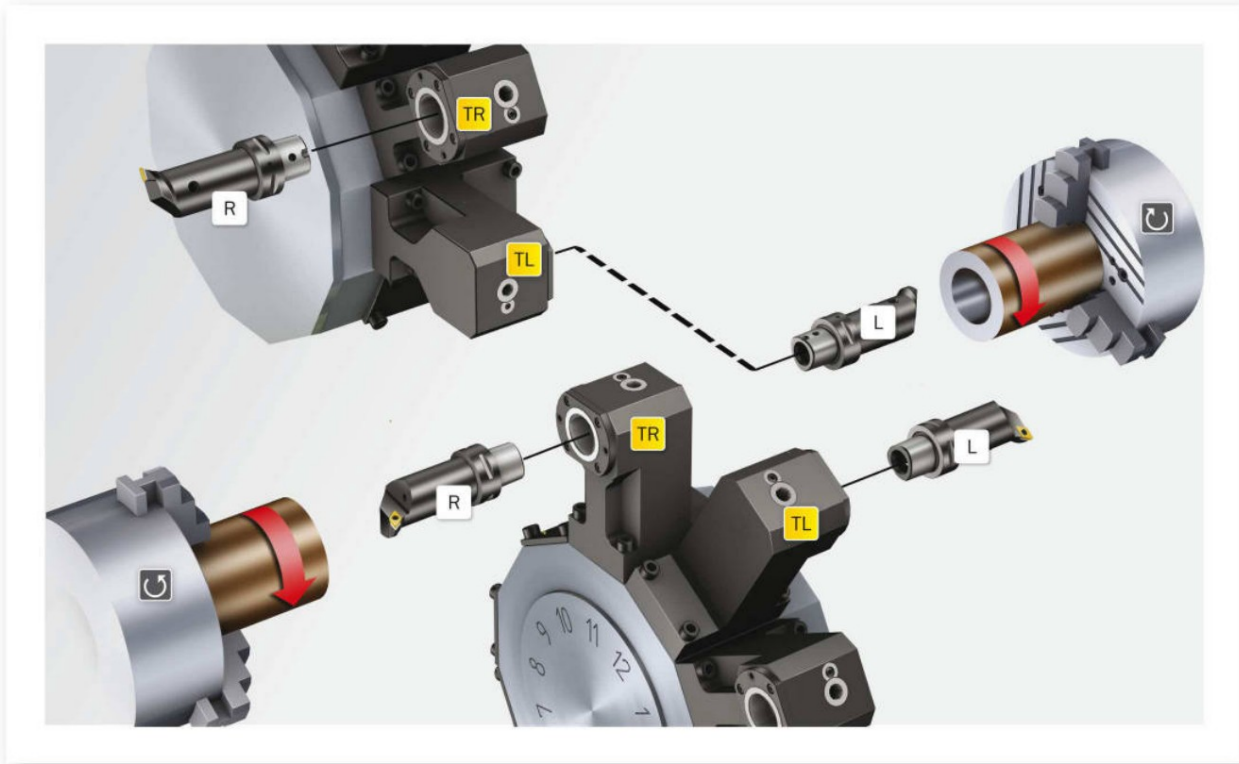

GRABO

h

Internal setup



External setup

-  Right hand cutting unit
-  Left hand cutting unit
-  Right hand clamping unit
-  Left hand clamping unit
-  Clockwise spindle rotation (M04)
-  Counter-clockwise spindle rotation (M03)

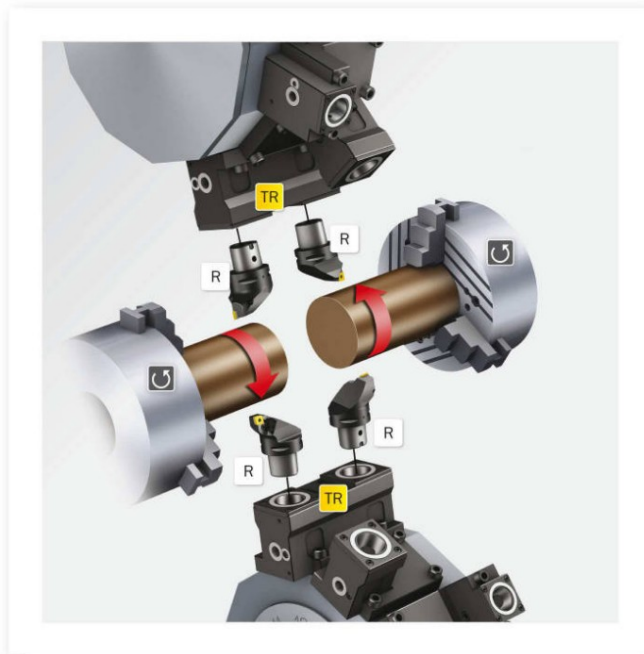

Aplicaciones de torneado

Portaherramientas	Insertar/Herramienta	Insertar
T-Max® P	 > CNMG	
CoroTurn® 107	 > CCMT	
T-Max® P	 > DNMG	
CoroTurn® 107	 > DCMT	
CoroTurn® 107	 > VBMT	
CoroThread® 266	 > 266	
CoroTurn® SL	 > CoroTurn® 107	 > TMCT 
CoroTurn® 107		
CoroTurn® 107		
Herramientas silenciosas™	 > CoroTurn® 107	 > VBMT 
Adaptador de taladro	 > CoroDrill® 870	 > Punta de broca intercambiable 
	 > CoroDrill® 881	 > Inserto de perforación indexable 
	 > FácilFix	 > barras aburradas 
		 > barras aburradas 
		 > barras aburradas 

Aplicaciones rotativas

Portaherramientas	Inserto/Pinza/Herramienta	Insertar
Coromant EH	 > CoroMill® 316	
	 > CoroMill® 390	 > R390 
	 > CoroMill® 490	 > 490R 
	 > CoroMill® 216	 > R216 
	 > CoroMill® 300	 > 300€ 
	 > CoroBore® 824	 > CXS 
	 > CoroBore® 825	 > TMCT 
CoroChuck™ 930	 > Pinza cilíndrica	 > CoroMill® Plura 
		 > CoroDrill® 860 
Portabrocas ER	 > pinza de emergencia	 > CoroMill® Plura 
		 > CoroDrill® 860 
CoroMill® 390	 > R390	