

# DMG MORI NLX 2500 (solo torreta estática)

Programa de portaherramientas



# NLX 2500 (solo torreta estática)

Programa Coromant Capto®

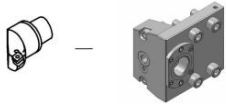
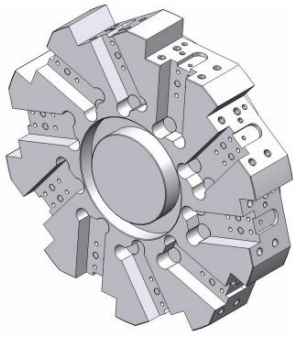

unidad de sujeción OD

C4	C4-TRE-MS-A	Estándar
C4	C4-TLE-MS-A	Estándar

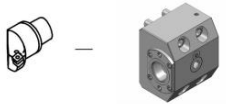

Unidad de sujeción de cara e identificación

C4	C4-TRI-MS-A	Estándar
C4	C4-TLI-MS-A	Estándar
C5	C5-TRI-MS-A	Estándar
C5	C5-TLI-MS-A	Estándar

# Cómo elegir la unidad de sujeción

Configuración interna

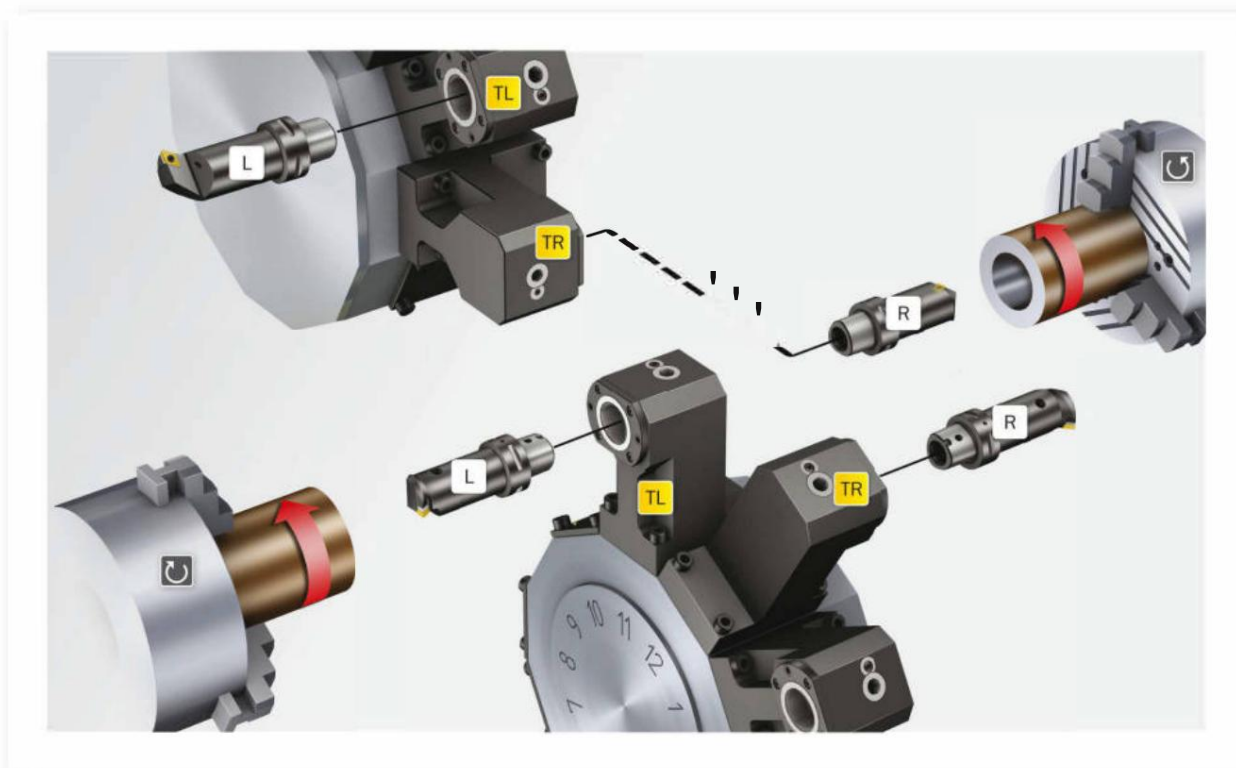

C

D

mi

Configuración externa

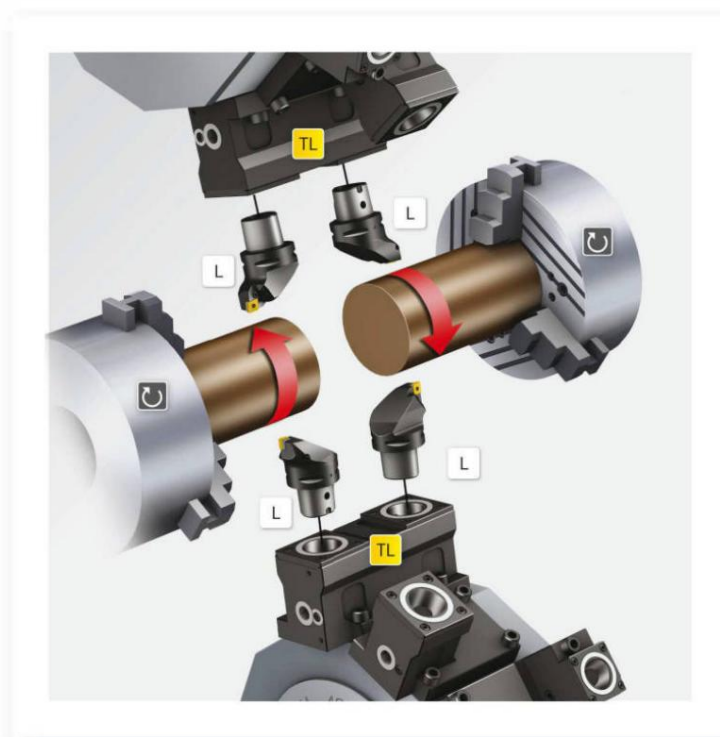

F





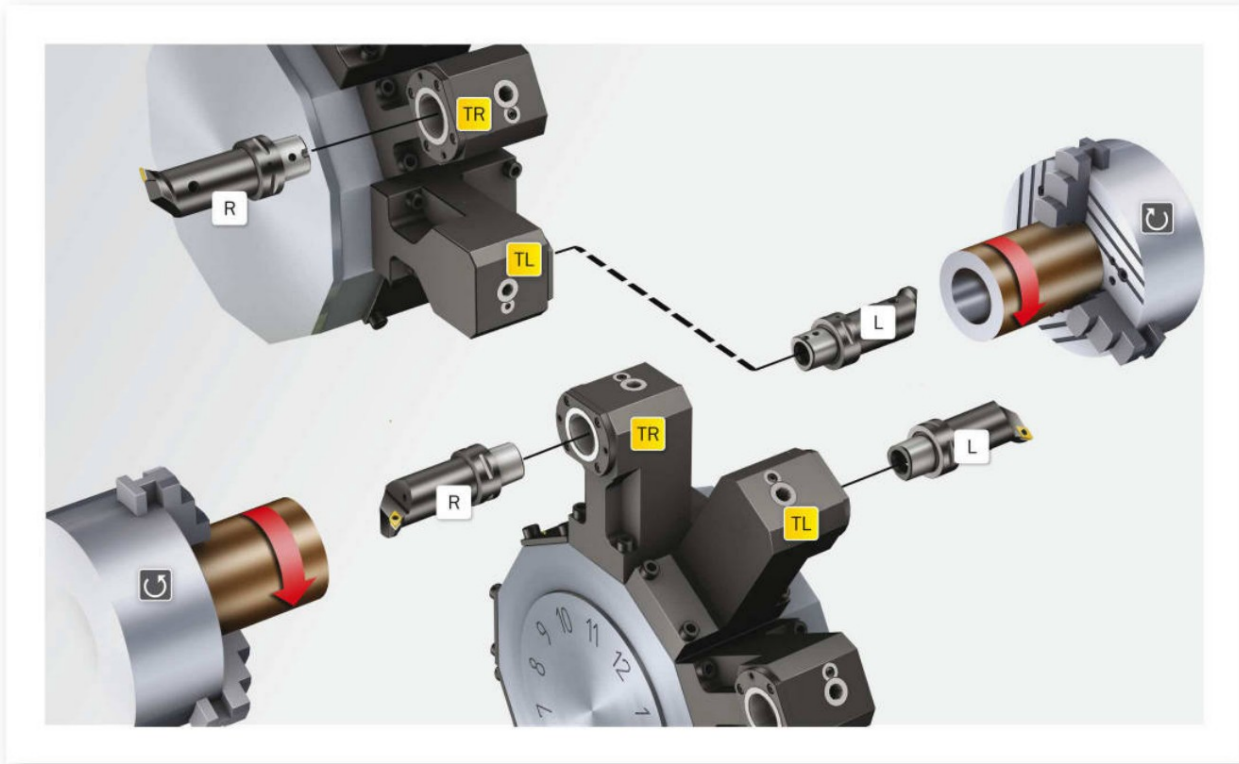

GRABO

h

### Internal setup



### External setup

-  Right hand cutting unit
-  Left hand cutting unit
-  Right hand clamping unit
-  Left hand clamping unit
-  Clockwise spindle rotation (M04)
-  Counter-clockwise spindle rotation (M03)

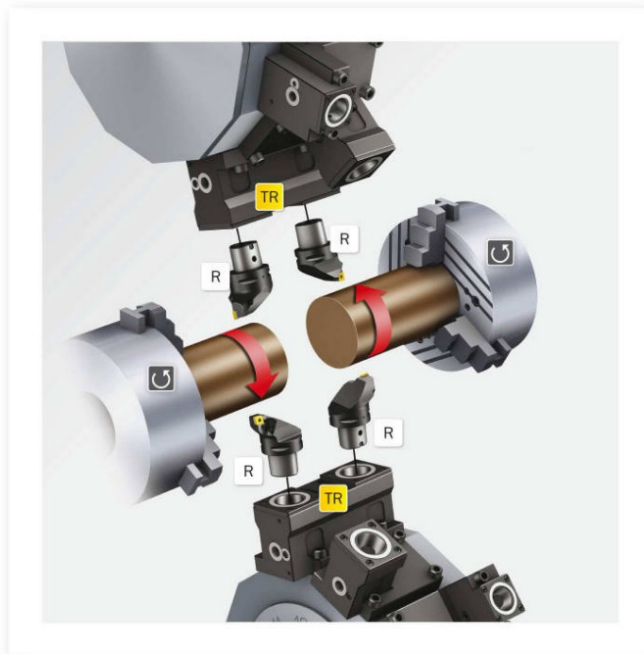

Aplicaciones de torneado

Portaherramientas	Insertar/Herramienta	Insertar
T-Max® P	CNMG	
CoroTurn® 107	CCMT	
T-Max® P	DNMG	
CoroTurn® 107	DCMT	
CoroTurn® 107	VBMT	
CoroThread® 266	266	
CoroTurn® SL	CoroTurn® 107	 TMCT 
CoroTurn® 107		
CoroTurn® 107		
Herramientas silenciosas™	CoroTurn® 107	 VBMT 
Adaptador de taladro	CoroDrill® 870	 Punta de broca intercambiable 
	CoroDrill® 881	 Inserto de perforación indexable 
	FácilFix	 barras aburradas 
		 barras aburradas
		 barras aburradas

Aplicaciones rotativas

Portaherramientas	Inserto/Pinza/Herramienta	Insertar
Coromant EH	 <ul style="list-style-type: none"> <li>CoroMill® 316</li> </ul>	
	<ul style="list-style-type: none"> <li>CoroMill® 390</li> </ul>	 <ul style="list-style-type: none"> <li>R390</li> </ul> 
	<ul style="list-style-type: none"> <li>CoroMill® 490</li> </ul>	 <ul style="list-style-type: none"> <li>490R</li> </ul> 
	<ul style="list-style-type: none"> <li>CoroMill® 216</li> </ul>	 <ul style="list-style-type: none"> <li>R216</li> </ul> 
	<ul style="list-style-type: none"> <li>CoroMill® 300</li> </ul>	 <ul style="list-style-type: none"> <li>300€</li> </ul> 
	<ul style="list-style-type: none"> <li>CoroBore® 824</li> </ul>	 <ul style="list-style-type: none"> <li>CXS</li> </ul> 
	<ul style="list-style-type: none"> <li>CoroBore® 825</li> </ul>	 <ul style="list-style-type: none"> <li>TMCT</li> </ul> 
CoroChuck™ 930	 <ul style="list-style-type: none"> <li>Pinza cilíndrica</li> </ul>	 <ul style="list-style-type: none"> <li>CoroMill® Plura</li> </ul> 
		<ul style="list-style-type: none"> <li>CoroDrill® 860</li> </ul> 
Portabrocas ER	 <ul style="list-style-type: none"> <li>pinza de emergencia</li> </ul>	 <ul style="list-style-type: none"> <li>CoroMill® Plura</li> </ul> 
		<ul style="list-style-type: none"> <li>CoroDrill® 860</li> </ul> 
CoroMill® 390	 <ul style="list-style-type: none"> <li>R390</li> </ul>	